

Reverse Osmosis

Drinking Water Systems

 ***Installation
Manual***

Reverse Osmosis Package Content



5-Stage Reverse Osmosis Assembly



4-Stage Reverse Osmosis Assembly



Reverse Osmosis Membrane



Drinking Water Storage Tank



Storage Tank Shut-Off Ball Valve



Feed Water Saddle Valve



Drain Saddle Valve



Filter Housing Wrench



Faucet Package

SECTION I. INTRODUCTION

Congratulations, you have just purchased one of the finest Reverse Osmosis Drinking Water Appliances available.

Like any other fine product, this appliance requires periodic maintenance in accordance with the schedule outlined below.

Recommended Filter Change Schedule*

1 - Pre-filter, 10", 5 Micron	6 Months
2 - Granulated Activated Carbon Post-filter	6 Months
3 - Reverse Osmosis Membrane	24 - 36 Months
4 - Pre-Carbon Filter For Chlorine Removal	6 Months
5 - Inline Carbon Adsorption Filter	6 Months

*Based on standard conditions.

Your new Reverse Osmosis (R.O.) Drinking Water system uses a combination of filtration technologies to reduce unwanted contaminants in a water supply. The following steps combine to give you the best in clear sparkling drinking water:

MECHANICAL FILTRATION - The sediment pre-filter will remove the larger particles such as silt, rust and scale. Its 5 micron (equal to 0.0002 inch) nominal rating helps to give maximum life to the R.O. Membrane and carbon filter.

ACTIVATED CARBON PRE FILTER(S) - The activated carbon in a pre-filter will remove any chlorine that may be present in the feed water. ***This pre-treatment is also necessary for membrane protection in chlorinated water.***

REVERSE OSMOSIS MEMBRANE - The R.O. Membrane is the heart of the filtration system. It is designed to reduce the dissolved mineral content of the water. Minerals picked up in the environment by the water are measured as Total Dissolved Solids (T.D.S.). In the Reverse Osmosis process, dissolved minerals are separated from the incoming water (Feed Water) to produce the product water (the Permeate). The excess minerals are rinsed to drain (the Reject Water). The spiral wound construction of the R.O. Membrane provides maximum surface area for water production and is less susceptible to fouling by particulate matter, turbidity and colloidal materials.

ACTIVATED CARBON POST FILTER - The Activated Carbon Post Filter cartridge contains carbon particles with a vast network of pores. The tremendous surface area of these pores (typically 800-1200 square meters per gram of carbon) gives the carbon very good adsorptive sites for chlorine as well as other substances that contribute to tastes and odors. The product water from the membrane as well as the holding tank passes through the Activated Carbon Post filter on the way to the Dispensing Faucet. The Activated Carbon Post Filter reduces tastes and odors that may pass through the system. It adds a final "polish" to the water.

INLINE CARBON ADSORPTION FILTER - This slow flow carbon filter is designed to reduce certain organic compounds and chloramines.

AUTOMATIC SHUT-OFF VALVE - The A.S.O. Valve senses when the product water tank is full and closes the feed water supply to prevent excess reject water from going to drain when the unit is not producing water.

SECTION II: PREPARATION

A. Major System Components

The following components comprise the R.O. Drinking Water System

1. A Reverse Osmosis assembly consisting of the white aluminum bracket, filter housings, automatic shut-off, membrane module and an in-line carbon filter.
2. A drinking water holding tank.
3. A faucet kit.
4. A plastic tubing kit with self-piercing saddle valve and drain clamp.
5. Other items necessary for installation may include wood screws or machine screws for mounting the R.O. assembly, or concrete anchors for hanging on basement wall, additional tubing or tube connectors, plastic wire ties for organizing tubing.

Note: For systems equipped with Quick Connect fittings, see last page.

B. Tools Recommended for Installation

The following tools will cover most of the installation sites encountered:

- 3/8" variable speed electric drill.
- Extension work light with outlet.
- Safety Glasses.
- 1-1/4" porcelain hole cutter kit.
- 1-1/4" Greenlee hole punch and 1/8" and 1/2" metal drill bits for pilot hole.
- Center punch and hammer.
- 1-1/4" wood bit.
- Assorted wood and metal drill bits including 7/32" metal drill bit.
- Phillips head and flat blade screwdrivers.
- 1/2", 9/16" and 5/8" open end wrench.
- 10" Crescent wrench with jaws taped to hold faucet.
- Teflon tape.
- Wide masking tape or duct tape.
- Plastic tubing cutter.
- Extra plastic tubing.
- Low range air pressure gauge.
- Bicycle hand air pump.
- Small bottle of liquid chlorine bleach.

C. Determine System Location

The R.O. system can be located under a sink or in a basement depending on space availability and the customer's preference. If a basement installation is selected, additional tubing, hardware and fittings may be needed and a hole will have to be made from inside the cabinet, through the floor, to the basement. Never install in an area of the home where temperature is freezing as damage to the system will result.

Considerations for an ice maker or other remote hookup should be determined, including routing and any additional tools, fittings, and tubing that may be required.

1. Faucet - The faucet should be placed near the sink where drinking water is normally obtained. Convenience of use (filling of water pitchers and glasses), and an open area beneath the faucet under the sink for attaching product tubing are considerations. A 2" diameter flat surface is required above and below the mounting site. The thickness of the mounting surface should not exceed 1-1/4". Watch for strengthening webbing on the underside of cast iron sinks.

2. Drinking Water Holding Tank - The holding tank may be placed where it is convenient within 10 feet of the faucet, under the sink or in an adjacent cabinet are best choices. If a longer run of tubing is required, the tubing should be the 1/2" diameter O.D. size to prevent a high pressure drop. Remember, these tanks can weigh up to 30 pounds when full of water, a firm, level area is required.
3. R.O. Assembly - The R.O. Assembly may be mounted on either the right or left side of the under-sink area or a cabinet. Mounting in the basement is also an option, one possible location is near the laundry/utility sink where cold potable water and drain access is handy. The mounting location should allow adequate clearance and accessibility for cartridge changes.
4. Feed Water Connection - The self-piercing feed water shut off valve should be located as close to the R.O. assembly as possible. **USE A POTABLE COLD WATER SUPPLY ONLY.** Softened water is preferred as it will extend the life of the R.O. Membrane.
5. Drain Connection - The drain saddle assembly is designed to fit around a standard 1-1/2" OD drain pipe. The drain saddle should always be installed above (before) the trap and on the vertical or horizontal tailpiece. Never install the drain saddle close to the outlet of a garbage disposal or plugging of the RO drain line may occur. If discharging into an utility sink or standpipe, an air gap of greater than 1" above the flood rim must be provided. Do NOT connect the system drain line to the dishwasher drain or near the garbage disposal.

D. Prepare The Area For Installation

To save time it is often advised to call the customer and request they clear under the sink prior to arrival. Otherwise, remove supplies from under the sink and stack them neatly away from the working area. Arrange a light for the work area, if necessary.

If a basement installation is called for, determine where components will be located and how they will be mounted. Special mounting brackets and hardware may be necessary to secure the system to a wall or ceiling joists.

Inspect cold water supply line and drain to determine if any special fittings, in addition to what is included in the kit, are required.

E. Prepare The Appliance For Installation

Open shipping carton and remove components. Check that all installation parts are present which includes the purification assembly, storage tank, faucet, installation hardware and tubing.

Check that the air supply in the empty tank is approximately 7 psi. Adjust if necessary.

SECTION III: INSTALLATION STEPS

All plumbing should be done in accordance with state and local plumbing codes.

NOTE: Some codes may require installation by a licensed plumber; check with the local plumbing authority prior to installation.

In restricted under-sink areas, it may be easier to install the faucet first. Allow adequate tubing lengths for any final component position.

A. Install The Faucet

See Figure 1 for Faucet Installation Diagram

The customer should be consulted before determining faucet location. The faucet should be positioned so that it empties into the sink and the spout swivels freely for convenience.

If the sink already has a hole provided that can accommodate the RO faucet, then no drilling is required and you can proceed to the section on mounting the faucet.

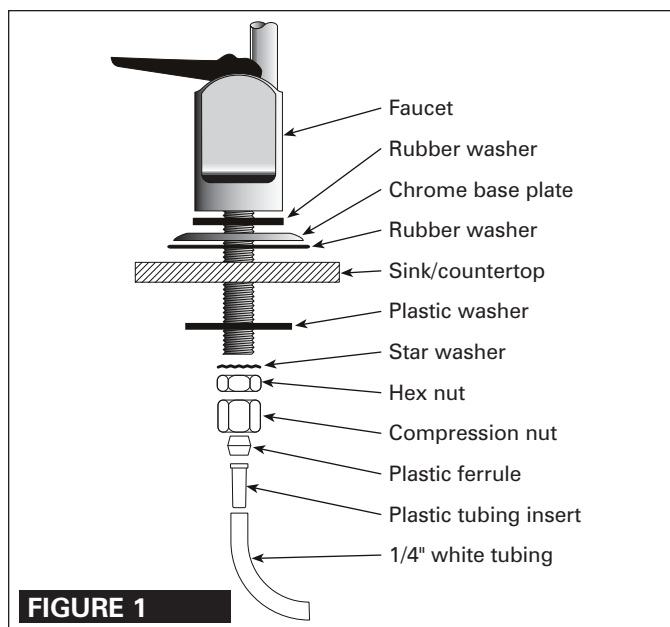

1. Make The Faucet Mounting Hole

IMPORTANT: It is mandatory that safety glasses be worn during sink hole drilling operations to prevent eye injury.

Before starting the hole making operation, always check below the sink so that nothing interferes with mounting the faucet such as reinforcing ribs, support brackets or cabinet construction.

STAINLESS STEEL SINK:

Recommended tools:

- Center punch
- Variable speed drill and high speed drill bits.
- Greenlee chassis punch 7/8" hole size (alternate 9/16" size may be used for non air gap faucet)
- Protective gloves

Procedure:

- a) Center punch a small indent at the desired faucet location.
- b) Slowly drill the required pilot hole for the chassis punch.
- c) Set up the chassis punch per instructions and tighten nut to cut the desired hole size.
- d) Clean up sharp edges with a file if necessary.

PORCELAIN/ENAMEL/CERAMIC ON SHEET METAL OR CAST IRON BASE:

Recommended tools:

- Variable speed drill
- Relton porcelain cutter tool set 7/8" size (alternate 9/16" size may be used for air gap or non air gap faucet)
- Plumber's putty

It is important to understand what is involved in this procedure. First, the glassy layer of porcelain must be penetrated through to the base metal. Second, a center disc of porcelain must be removed while protecting the surrounding porcelain against chipping or fracturing. Third, the base metal must be drilled through to complete the hole.

Procedure:

- a) Mark the center for the 7/8" hole
- b) Form shallow putty dam around hole area and fill with enough water to lubricate carbide drill bit.
- c) Carefully drill pilot hole through porcelain/enamel and base metal using carbide type pilot drill.

IMPORTANT: Always operate drill with light pressure at slow speed (300-400 rpm).

- d) Insert pilot tip of spring-loaded porcelain cutter into pilot hole.
- e) Drill porcelain/enamel using spring-loaded porcelain cutter, making certain a complete ring has been cut through the porcelain/enamel to the metal base.
- f) Change to the metal cutter. With slow speed and light pressure, cut away the inner porcelain/enamel disc down to base metal. Make certain that the cutter does not touch outer rim of the cut porcelain/enamel. Continue with this bit to cut through metal until sink has been completely penetrated.

IMPORTANT: When using a porcelain cutter it is critical to take precautions that it is always in a sharpened condition. Dull cutters are known to chip sinks.

2. Mount The Faucet:

- a) Familiarize yourself with all components shown in the faucet diagram.
- b) Disassemble hardware from the threaded nipple, except for chrome base plate and rubber washer.

NOTE: Rubber washer may be replaced with bead of plumber's putty for neater appearance.

- c) Connect length of standard 1/4" tubing to faucet. Push on firmly until it seats.
- d) Feed the threaded nipple through sink/counter mounting hole and orient the faucet as discussed with the customer.
- e) From below sink/counter assemble the black plastic washer, star washer and hex nut on threaded nipple and tighten by hand.
- f) After rechecking faucet orientation, tighten hex nut (9/16" wrench or deep socket) until faucet feels secure.
- g) From above the sink make any minor orientation corrections by turning the faucet with a padded adjustable wrench.

Note: Flats on chrome faucet may be used for tightening with an adjustable wrench. Use care not to mar chrome finish.

B. Install the Feed Water Valve and Tubing

The saddle tapping valve supplied is designed for use with 3/8" to 1/2" OD soft copper supply tubing (plain or chromed), rigid metal pipe, or CPVC plas-

tic pipe. Do not use with flexible ribbed supply tubing which has too thin a wall thickness and requires special hardware.

Saddle Valve Installation

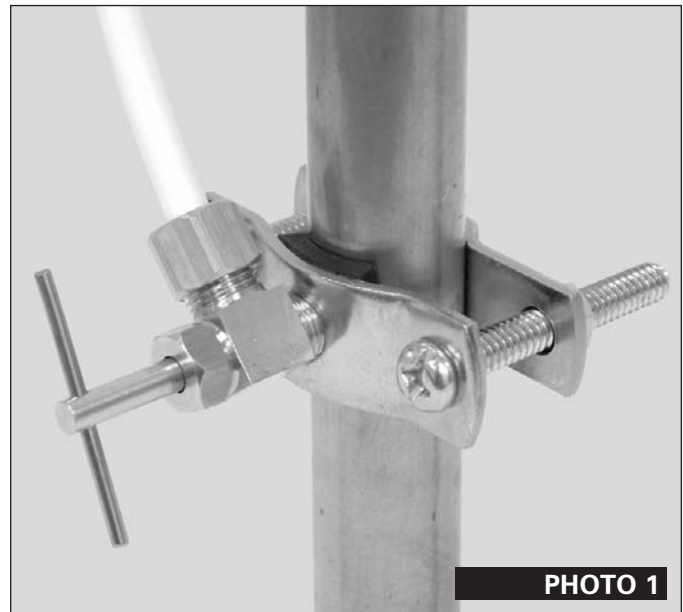

PHOTO 1

SOFT COPPER TUBING INSTALLATIONS:

- 1) Turn off cold water valve under the sink, or main valve for the house.
- 2) Before installing saddle tapping valve, make sure piercing lance does not protrude beyond rubber gasket.
- 3) Assemble saddle tapping valve on copper tubing. Tighten clamp.
- 4) To pierce soft copper tube, turn handle clockwise until it is firmly seated. The valve is closed in this position.
- 5) Turn on main supply valve to pressurize cold water line. Check for leaks. With a wrench snug nut/seal around valve stem.

NOTE: For basement installations the existing feed water tubing may have to be longer to reach feed valve.

- 6) Connect one end of the tubing to the feed water valve using brass compression nut and plastic sleeve.

RIGID METAL PIPE AND CPVC PLASTIC PIPE INSTALLATIONS:

- 1) Turn off cold water supply valve and drain the line to prevent spillage.
- 2) Drill 3/16" hole at the desired location. To prevent shock hazard, use a battery operated drill.

- 3) Before installing saddle tapping valve, make sure piercing lance does not protrude beyond rubber gasket.
- 4) Assemble saddle tapping valve on copper tubing.
- 5) Turn saddle valve handle clockwise to close valve. With a wrench tighten nut/seal around valve stem.
- 6) When you wish to open valve and supply cold water to the unit, turn valve handle counterclockwise.
- 7) Connect one end of the tubing to the feed water valve using brass compression nut and plastic sleeve.

NOTE: For basement installations the existing feed water tubing may have to be longer to reach feed valve.

C. Prefill and Sanitize the Storage Tank

Prefilling the tank is always recommended so there is pressure to check for leaks and several gallons of water to flush carbon post filter. Tanks are furnished with a special disinfectant and only require filling with water for 15 minutes to be completely sanitized. It is important to use a sanitizer when prefilling tank so the solution can sanitize the tubing, fittings, and faucet at the time of installation and startup.

- 1) Insert free end of feed water tubing into the fitting on the storage tank.
- 2) Open feed water valve and tank valve and allow tank to fill (about 3 minutes).
- 3) Turn off feed water valve, tank valve, remove tank from tubing and set tank aside (15 minutes minimum).

D. Install the Drain Connection

IMPORTANT: Before starting this procedure, inspect the condition of the drain piping, especially in older homes where the traps and tailpieces can be deceptively thin and frail. If in poor condition, it is wise to inform the customer that the condition should be remedied.

The drain saddle assembly is designed to fit around a standard 1-1/2" OD drain pipe.

The drain saddle should always be installed above (before) the trap and on the vertical or horizontal tailpiece. Never install the drain saddle close to the outlet of a garbage disposal or plugging of the RO drain line may occur.

- 1) Peel adhesive covering from the back of foam square gasket and line up with the hole in the saddle drain and apply. This gasket provides a leak proof seal on the drain stand pipe.
- 2) Position both halves of drain saddle at desired location on drain pipe.
- 3) Use bolts and nuts to clamp drain saddle onto drain pipe. Do not over tighten and make sure there is equal space between saddle halves on each side.
- 4) Carefully drill hole through threaded fitting of drain saddle (as shown in Photo 2) being careful not to drill through opposite side of drain pipe.
- 5) Wrap teflon tape on thread of fitting, insert drain tubing into compression nut and tighten onto drain saddle.

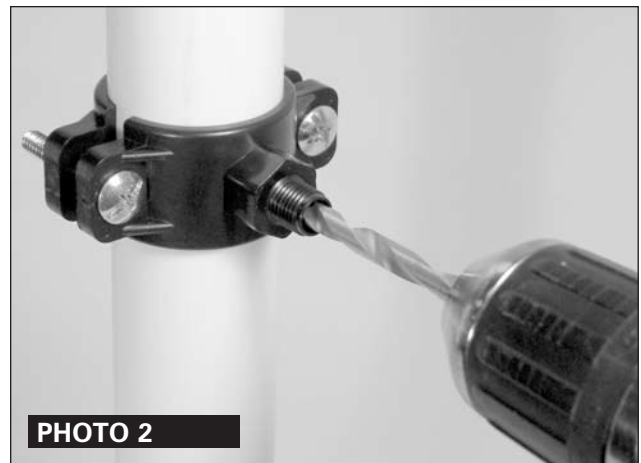

D. Install the R.O. Membrane

The RO Membrane has been shipped to you in a special preservative. Unscrew the tubing from the end cap of the membrane housing. Then unscrew the end cap from the membrane housing on the appliance, insert the membrane as illustrated below. The O-rings on the product water tube of the membrane **MUST FULLY SEAT** in the membrane housing for proper operation. Also make sure that the Brine Seal on the membrane seals with no gaps or wrinkles inside the membrane housing. Once the membrane is installed, replace the end cap and reconnect the tubing.

To insure that all the special preservative is flushed from the system before use, **DO NOT** use the first two tankfuls of water produced by the system.

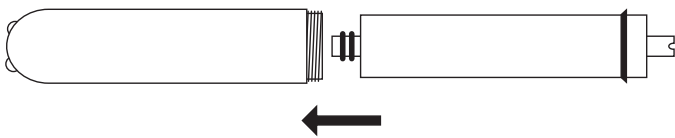

F. Make Initial Tubing Connections

It is advantageous to make some of the tubing connections at this time, since the undersink work area is not so cramped and access to the components is easier.

G. Install the Purification Assembly and Storage Assembly

The purification assembly is usually mounted to the right or left sink cabinet sidewall, taking into consideration the space available and the tank location. Generally, the tank is placed in the rear of the cabinet while the purification assembly is positioned toward the front for cartridge accessibility.

To mount the purification assembly elevate at least 2" off the cabinet floor and, while keeping level, mark the location of the mounting holes on cabinet sidewall. Make small pilot holes with an awl or drill and screw in the two mounting screws, leaving just enough protruding to allow bracket mounting slots to slide over them.

NOTE: If the cabinet sidewalls are not of solid construction, the purification assembly can be set on the cabinet floor and held against the sidewall with the mounting screws.

The tank may be oriented either vertically or horizontally. It is generally placed to the rear of the cabinet but can be set in the front center (between the sink basins) for ease of access if space permits.

H. Make Final Tubing Connections

With all of the components in place, the final tubing connections can be made. When routing tubing between components, several guidelines should be observed.

- Tubing runs should generally follow the contour of the cabinets rather than interfere with the cabinet storage area.
- Strive for neatness and an orderly tubing "flow" using fasteners (e.g. insulated staples) to secure the tubing. Cut tubing to the desired length.
- Arrange the tubing so there are no sharp bends and leave some "play" in the tubing for ease of servicing.
- Try to keep the tubing from the purification assembly to the tank and faucet as short as practical for good flow.

I. Install Ice Maker Hookup (optional)

Note: Check with refrigerator manufacturer for compatibility with your refrigerator model.

The RO drinking water appliance can be connected to any standard refrigerator ice maker or ice maker/water dispenser. It should never be connected to a commercial type bar ice maker.

Hooking up an ice maker involves connecting a tee with shut off valve into the faucet tubing and routing tubing over to the refrigerator. **Do not** hook-up to existing copper tubing.

Before turning off the existing tap water supply to a refrigerator ice maker, always shut off the ice maker first (usually by lifting the lever arm above the bin to the uppermost position). The ice maker should only be turned on again after the RO system has been drained several times and the tank has a full supply of water.

NOTE: Before any service is performed on the RO system, always turn off ice maker valve and the ice maker unit. Only turn on when system is operating and tank is full.

J. Start Up the System

- 1) Double check that all connections are secure.
- 2) Turn on feed water valve and check for leaks. If any leaks are noted, turn off valve and correct before proceeding.
- 3) Turn on storage tank valve and open faucet until a steady stream of water flows. Close faucet, wait at least 5 minutes and carefully check for leaks. Correct as necessary.

K. Flush System of Preservative and Check Operation.

- 1) Lift faucet handle and allow tank to drain completely of sanitizing solution. Do Not Use This Water. When tank is empty, the faucet will steadily drip. This is the rate water is processed by the RO system.
- 2) With faucet handle in "up" position, measure the rate of the steady drip from spout. Use a graduated cylinder (in milliliters) and watch with a second hand to calculate approximate production in gallons per day (milliliters per minute X 0.38 = gpd). Proceed to check reject flow rate by disconnecting tubing at drain connection and measure as per above. The ratio should be a minimum of 2.5 (reject) to 1 (product).
- 3) Close faucet and re-inspect system for leaks. Instruct customer to wait at least 4 hours and drain tank again. The water should be discarded as it may contain some preservative/disinfectant solution.
- 4) System should be ready to use as soon as the tank refills. If any objectionable taste is noticed after second tank draining, instruct customer to wait and drain tank the following day. Only at this time should an ice maker be turned on if one is connected to the system.

SECTION IV: OPERATION & MAINTENANCE

A. Normal Operation

1. It is normal for the Total Dissolved Solids (T.D.S.) of the water to be higher than normal during the first 5 gallons of operation, this is due to the sanitizing solution and the new Post Filter. After this water is rinsed to drain, the removal rate should stabilize at a value greater than 75%. Water pressure affects the production rate and quality.
2. R.O. systems produce drinking water at relatively slow rates, it can take up to 8 hours or more to fill the holding tank. Normal operation is to let the Holding Tank fill with water and then draw water as is needed. When the pressure in the Holding Tank falls to a given pressure(as the water is being used) the Automatic Shut Off Valve (A.S.O. Valve) will start water production and the system will refill the Holding Tank. When the Holding Tank is full and no water is being used, the A.S.O. Valve will automatically shut off the

feed water to conserve water.

The more water that is used (up to the capacity of the system) the better the R.O. system will function. Utilize other uses for the water, such as flowers, pets and rinsing glassware.

After periods of non-use, such as a week's vacation, it is better to empty the holding tank and allow the system to produce fresh water for use. If the system is not used for 3-4 weeks or longer, it is a good idea to re sanitize the system and to change the Activated Carbon and Sediment Filters.

B. Changing Filters

NOTE: THIS R.O. SYSTEM CONTAINS FILTERS WHICH MUST BE REPLACED AT REGULAR INTERVALS TO MAINTAIN PROPER PERFORMANCE. USE ONLY FACTORY APPROVED FILTERS.

Please see Page 1 for the recommended interval for changing the filters. Local conditions may dictate more frequent changes.

Use a drip pan to catch any water that may spill when the Filter Housing are removed.

- 1) Close the Saddle Tapping Valve by turning fully clockwise and open the Dispensing Faucet by lifting the handle. Allow the Holding Tank to empty.
- 2) Loosen and remove the appropriate Filter Housing. Discard the cartridge(s).
- 3) Wash the inside of the Housing(s) using a mild detergent and a soft cloth. Do not use abrasive cleaners or pads. Thoroughly rinse all soap from the housing before reassembly.
- 4) To sanitize the system and replace the filter cartridge(s):

NOTE: The system should be sanitized before installing the Activated Carbon Post Filter Cartridge.

- a) Use a good quality unscented 5-1/4% liquid bleach such as Clorox.
- b) Add one cap full of bleach (this is 2 tsp. or 10 ml) to the Sediment Filter Housing. Install the Sediment Prefilter only. Check the Housing O-ring for proper position in its groove, replace Sediment Filter Housing on R.O. assembly.
- c) If your R.O. system has a Pre Carbon Filter Housing, add one cap full of bleach. Carefully fill the housing with tap water and temporarily install the housing, without the Activated Carbon Pre Filter.

- d) Add one cap full of bleach to the Activated Carbon Post Filter Housing. Carefully fill the housing with tap water and temporarily install the housing, without the Activated Carbon Post Filter.
 - e) The Dispensing Faucet should be open, slowly open the Saddle Tapping Valve on the Feed Water Line.
 - f) As soon as water begins to drip out of the Dispensing Faucet, close the Faucet.
 - g) Let the system stand for 15 minutes.
 - h) At the end of 15 minutes, in the following order, close the Saddle Tapping Valve, close the Holding Tank Valve and open the Dispensing Faucet to release the pressure.
 - i) Remove the Post Carbon Filter Housing and empty (Repeat procedure if your system has a Pre Carbon Filter Housing). Remove any wrapping/packaging from carbon cartridge (s)
- and install in housings. Check the O-ring to insure that it is positioned properly in its groove and replace Housing(s) on R.O. unit.
 - j) Disconnect the yellow product water tubing that runs from the Holding Tank. Put 50 drops of bleach (this is 1/2 tsp. or 3 ml) into the tubing and reconnect it.
 - k) Slowly open the Saddle Tapping Valve. When water begins dripping out of the Dispensing Faucet, in the following order, close the Faucet and then open the Holding Tank Valve.
 - l) Do not open the Faucet for at least 8 hours.
 - m) Discard the first two full tanks of water produced, they will contain chlorine.
 - n) When the Faucet is first opened, expect air and carbon fines (very fine black powder), from the new carbon filter (s) to be rinsed out. This is normal for the first tank of water.

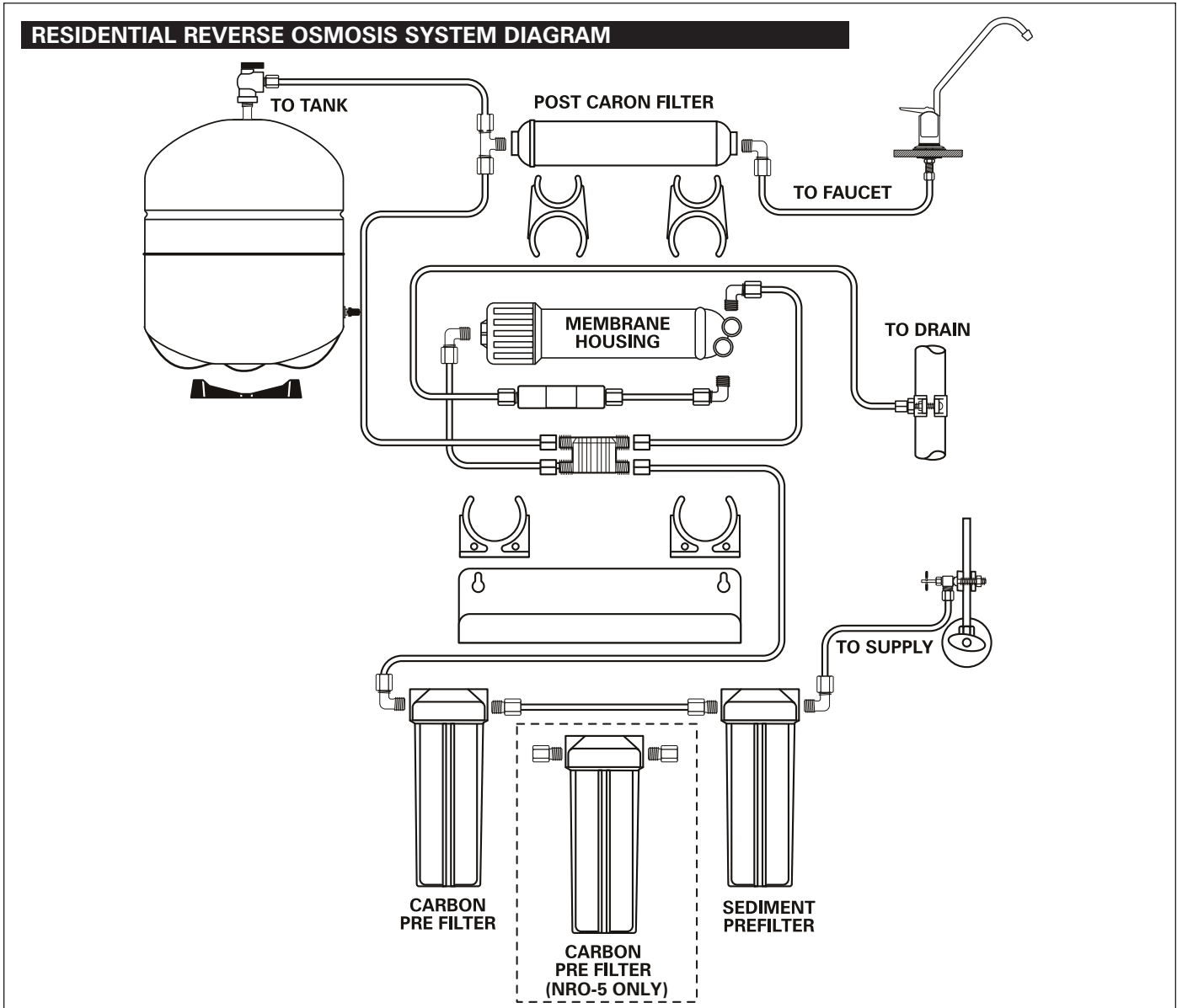

For System Equipped with Quick Connect Fittings...

Your new Reverse Osmosis Drinking Water Appliance may be outfitted with the new generation of user-friendly quick connect push-in fittings. Proper use of the fittings is shown in the diagrams.

It is important that the tubing selected for use with these connectors be of high quality, exact size and roundness, and with no surface nicks or scratches. If it is necessary to cut the tubing, use a plastic tubing cutter or sharp razor knife. Make a clean, square cut.

An optional blue locking clip is installed in certain fittings to provide extra security. Remove this clip first before trying to remove tubing by sliding away from fitting.

Should a leak occur at a fitting, the cause is usually defective tubing.

- To fix:
- Relieve pressure
 - Release tubing
 - Cut off at least 1/4" from end
 - Reattach tubing
 - Confirm connection is leak free

To Attach Tubing...

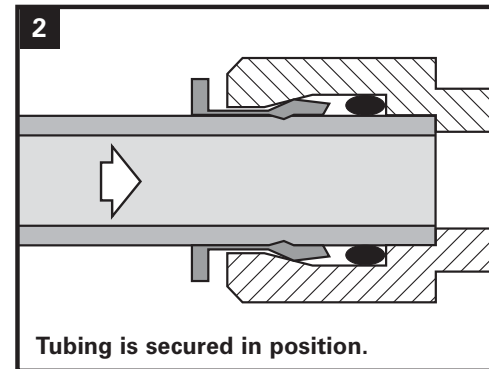
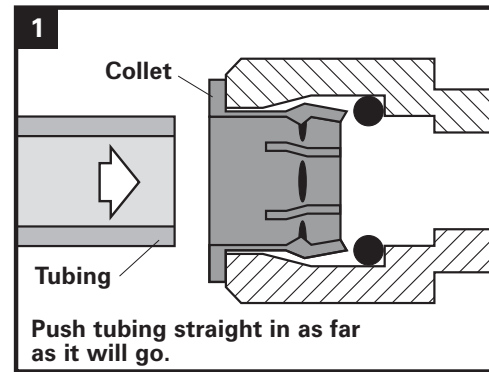

To Release Tubing...

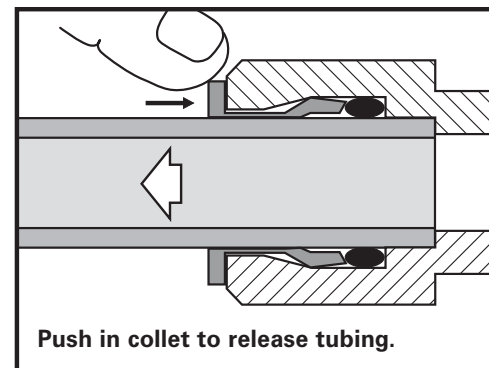

Optional Locking Clip...

